



FREE UK DELIVERY



SITE SURVEYS



10 YEAR GUARANTEE



INSTALLATION SERVICE



MADE IN BRITAIN

TWO TIER CYCLE RACK

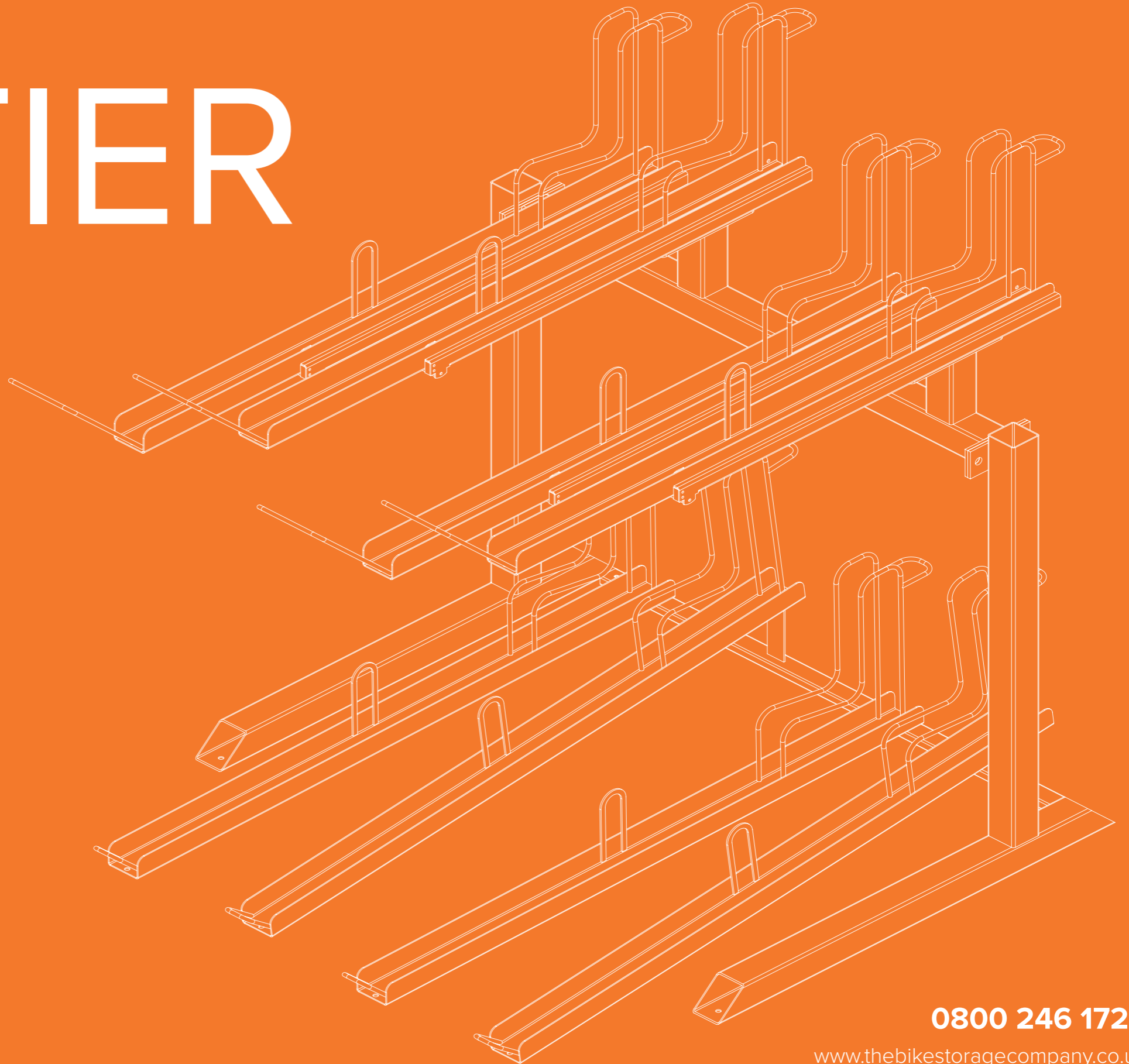

THE
BIKE STORAGE
COMPANY

0800 246 1723

www.thebikestoragecompany.co.uk

hello@thebikestoragecompany.co.uk

306 Harbour Yard, London, SW10 0XD

TWO TIER CYCLE RACK



Hot Dipped Galvanised Handles

Hot Dipped Galvanised handles to BS EN ISO 1461:2022 for optimal durability. If you're looking to create a more personalised bike storage zone we can provide Framework Powder Coating to any RAL colour.



EasyGrip Handles

Access to the second tier of the rack is aided by the EasyGrip handles, lightweight steel and gas-assisted mechanisms that take the weight of the bike during the mounting and unmounting process.



TOP

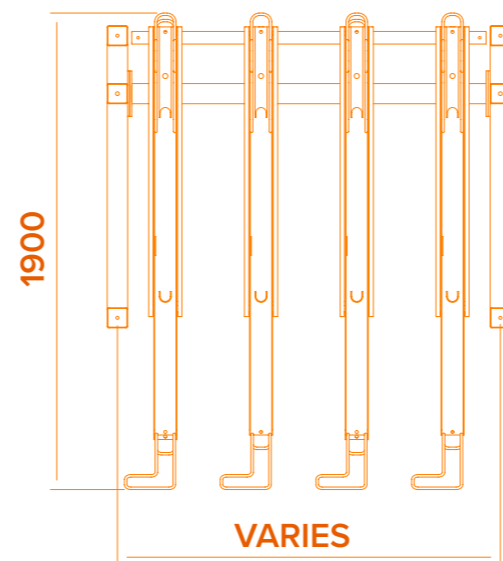

SIDE

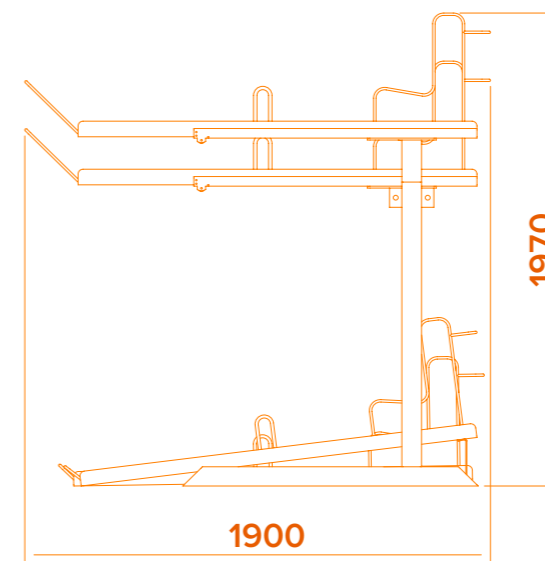

FRONT

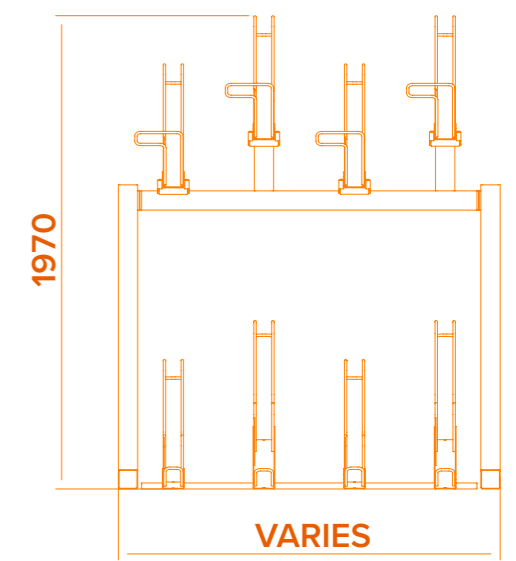

The Two-Tier Bike Rack offers excellent space-saving opportunities while providing your cyclists with a user-friendly experience. Delivering superb value, the Two Tier Bike Rack has become the rack of choice for any area requiring high-density bike storage, including stations, universities, shopping centres, car parks, and offices. The rack's channels can support any bike with a maximum tyre width of 65mm; the ability to lock both the wheels and the frame to the rack also enables you to guarantee high-security parking and BREEAM Compliant.

FEATURES

- Free Delivery
- UK Manufactured
- Counterbalance lifting mechanism
- Minimum height required is 2500mm
- Single or back-to-back versions are available
- Hot Dipped Galvanised to BS EN ISO 1461:2011
- Complete site visit and layout design provided free of charge
- Code for Sustainable Homes compliant and BREEAM Compliant
- Allows for both the wheels and the frame to be locked to the rack
- Manufactured against your dimensions and room layout at no extra cost
- 375mm spacing between racks and a staggered height design allows for space utilisation and ease of access

OPTIONAL EXTRA

- EasyGrip red or CHS EasyGrip handles available
- Gas assisted upper level
- Powder coating (excluding inner channel)
- Intergrated back-to-back channel arrangement
- Lower level channels (rack is provided as standard with Sheffield Stands for lower level)



LAYOUT 2

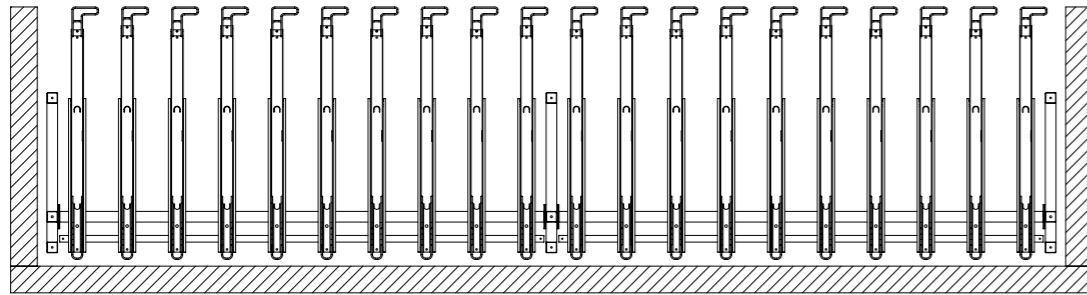
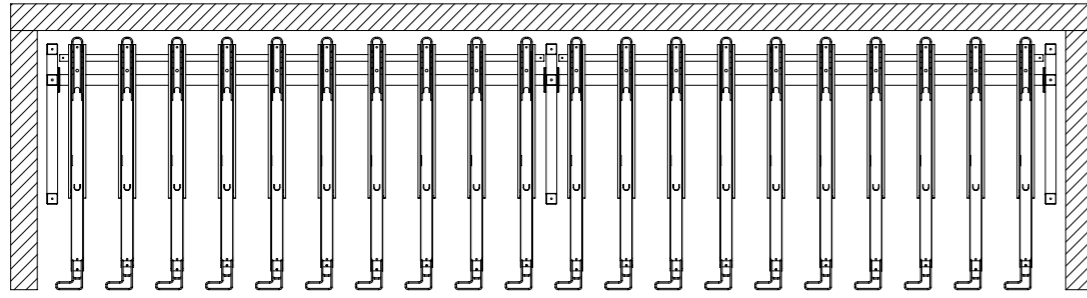

TOP

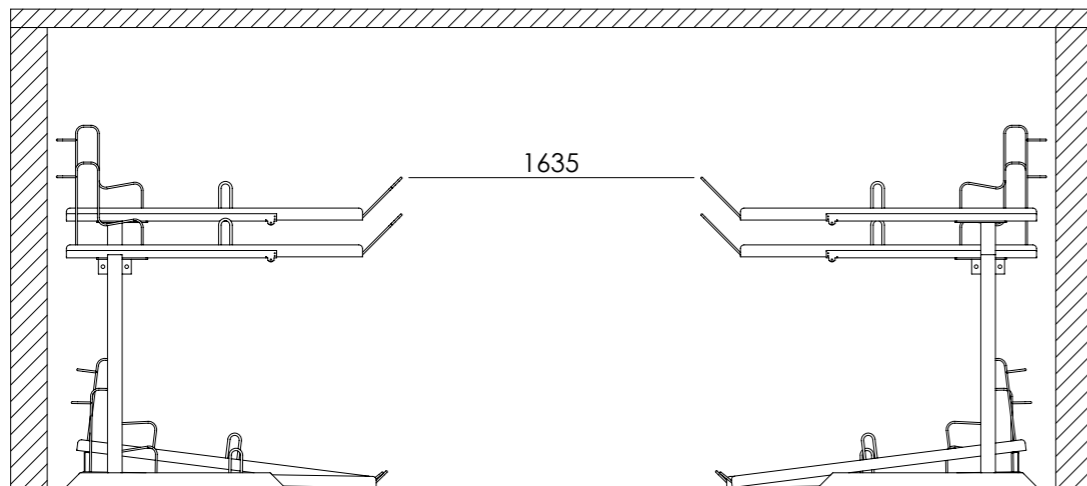

SIDE

LAYOUT 3

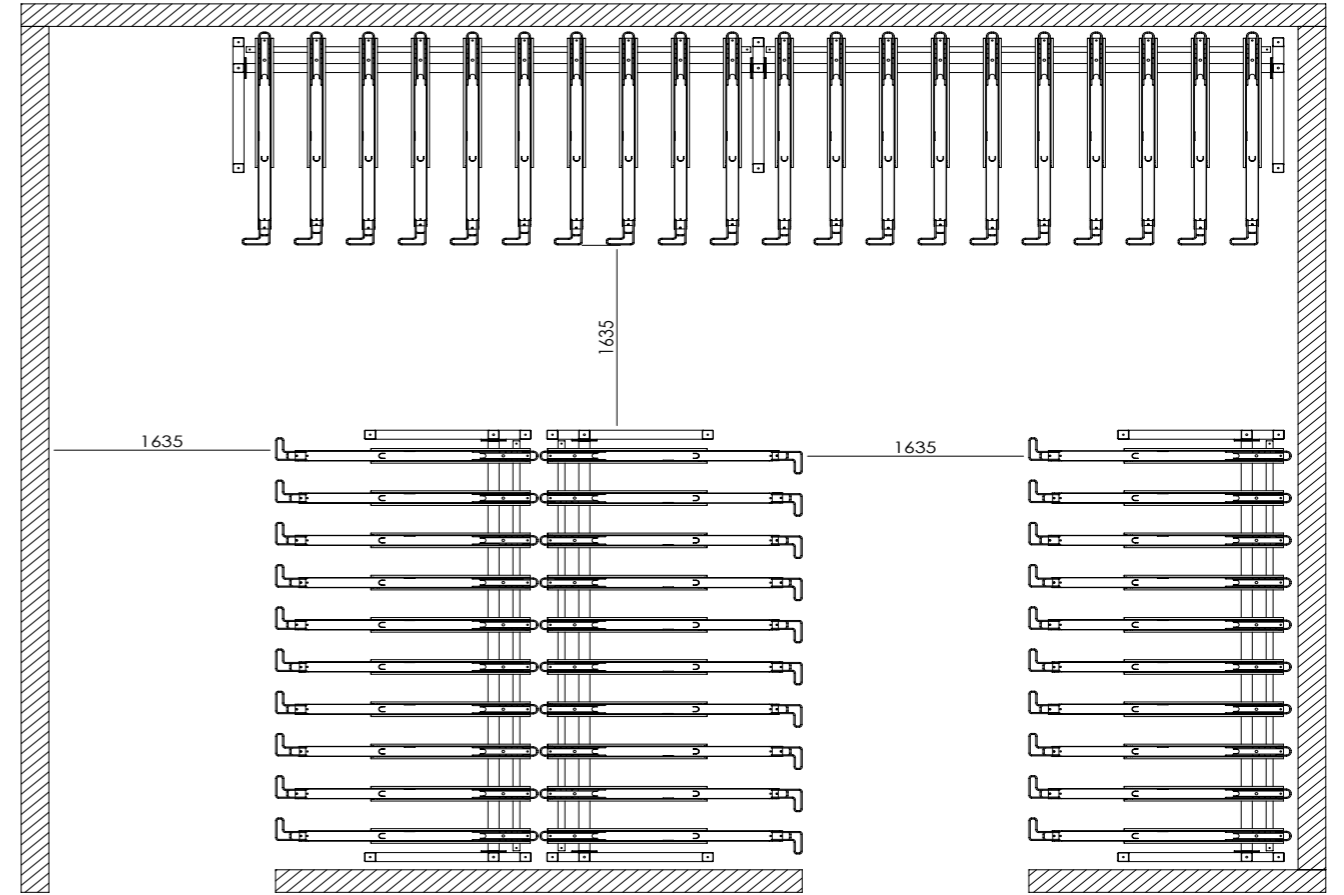

TOP

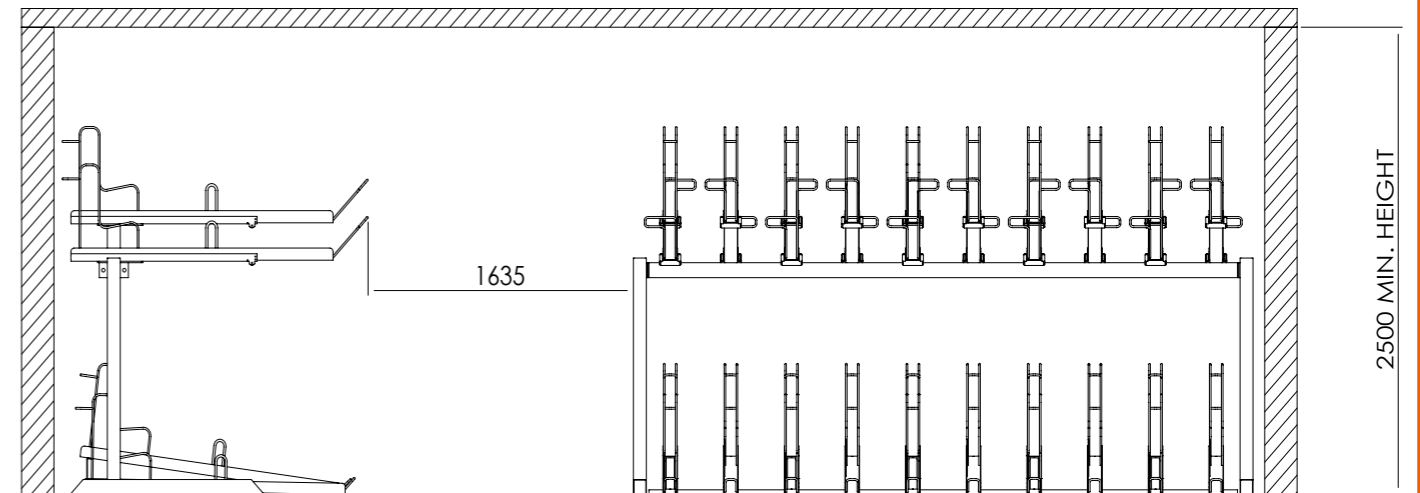

SIDE